

### Input data

System of measurement		Metric
Input type		Coupling for electric motor
Input speed	[rpm]	1400
Output speed	[rpm]	35
Ratio (i=)		40
Frequency	[Hz]	50
Input options		IEC
Requested input power	[kW]	0.09
Service factor		1.1
Rated Power P1	[kW]	0.1

### Output data

#### Gear unit **F RS 28 PC 40 56 B14 AC 14 B3**

Type		RS - Worm speed reducers
Input type		F (Elastic coupling)
Size		28
Ratio (i=)		40
Input flange		B14
Mounting position		B3
Input speed	[rpm]	1400
Output speed	[rpm]	35
Rated output torque	[Nm]	15.23
Service Factor		1.1
Efficiency		0.62
Inertia moment	[kgm <sup>2</sup> ]	0.000005

#### Gear unit configuration

Output shaft		Hollow output shaft
Fixing		Shaft mounting
Version		PC

#### Output radial and axial loads

Ball bearings output radial load	[N]	700
Taper bearings output radial load	[N]	1050
Ball bearings output axial load	[N]	140
Taper bearings output axial load	[N]	210

#### Accessories

Hollow output shaft		AC 14
---------------------	--	-------

#### Electric motor coupling

Size		56 B4
Poles n.		4
Power	[kW]	0.09

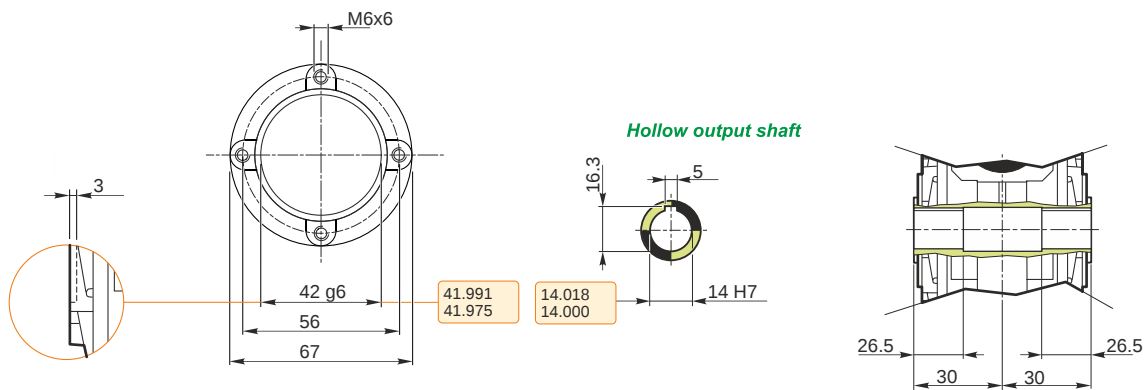
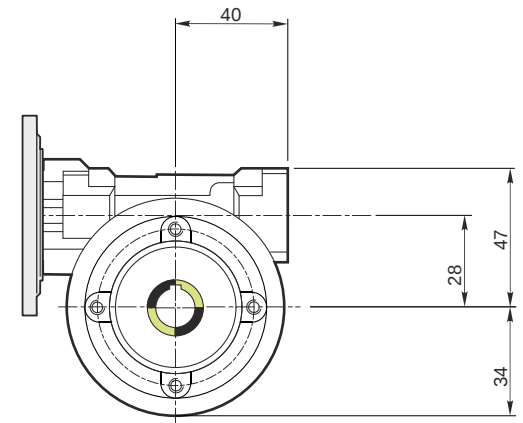
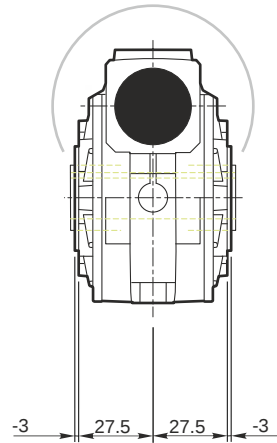
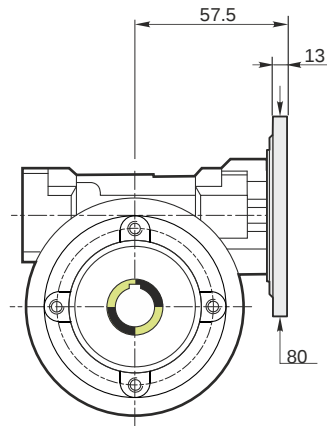

**F RS 28 PC 40 56 B14 AC 14 B3**

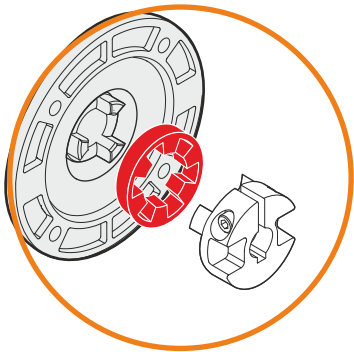
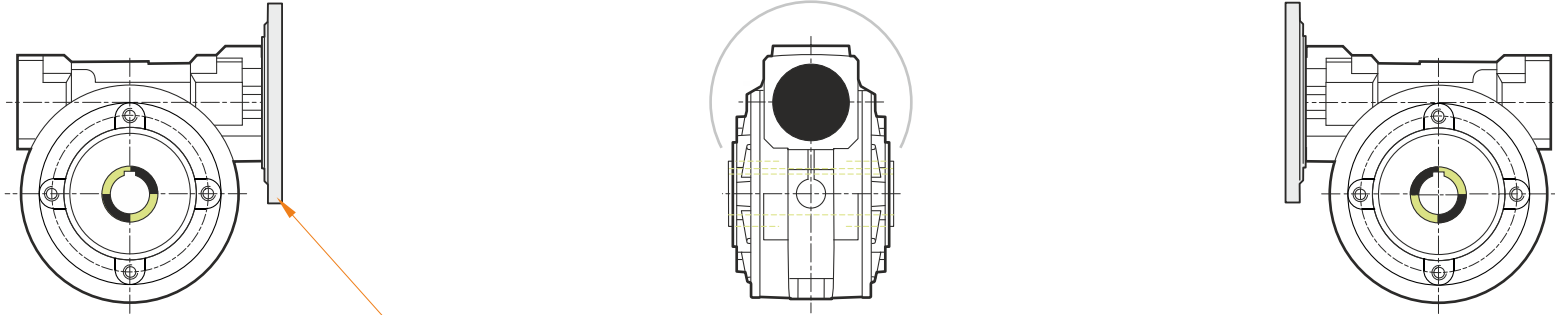

This gear unit is provided with an elastic coupling motor fitting

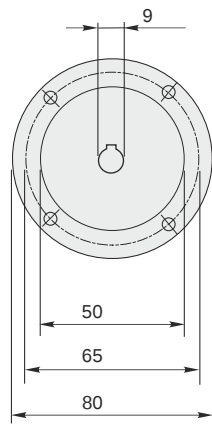

**Mounting positions**

**B3**

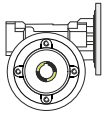

**B6**



**B7**



**B8**

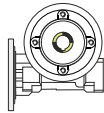

**V5**

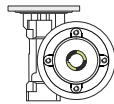

**V6**

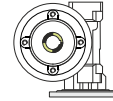

0.03



← Oil quantity [litres]

Lubricant type: Long life synthetic oil ISO VG320

**Direction of rotation**

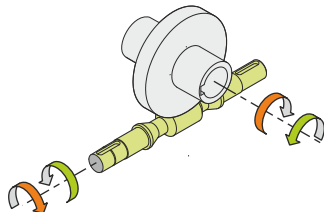

**Weight**

Gear unit [kg] 1.1

**Gearing data**

Axial module	1.1
Number of starts	1
Lead angle	5° 14'
Pressure angle	20°

**Backdriving**

Static self-locking  
Slow back-driving in case of vibrations  
Low dynamic back-driving