

Input data

System of measurement		Metric
Input type		Gear motor
Input speed	[rpm]	1400
Output speed	[rpm]	31.25
Ratio (i=)		44.8
Frequency	[Hz]	50
Input options		IEC
Requested input power	[kW]	1.1
Service factor		1.1
Rated Power P1	[kW]	1.18

Output data

Gear unit **M TA 80/70 B3 10 44.8 90 B14 AC 28 MT 1.1 kW 90 S4 B14 X3**

Type		TA - Worm speed reducers
Input type		M
Size		80/70
Ratio (i=)		44.8
Gearbox ratio		7.00
Pre-stage ratio		6.40
Input flange		B14
Input speed	[rpm]	1400
Output speed	[rpm]	31.25
Rated output torque	[Nm]	268.93
Service Factor		1.1
Efficiency		0.8
Inertia moment	[kgm ²]	0.000263

Gear unit configuration

Output shaft		Hollow output shaft
Fixing		Universal
Version		B3
Attachment position		10

Output radial and axial loads

Ball bearings output radial load	[N]	4900
Taper bearings output radial load	[N]	6550
Ball bearings output axial load	[N]	980
Taper bearings output axial load	[N]	1310

Accessories

Hollow output shaft		AC 28
---------------------	--	-------

Electric motor

Size		90 S4
Poles		4
Power	[kW]	1.1

Electric motor configuration

Motor flange		B14
Terminal box position		X3

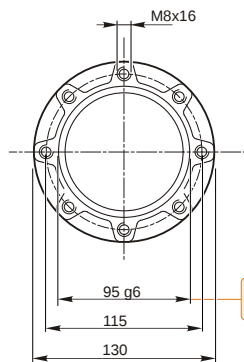
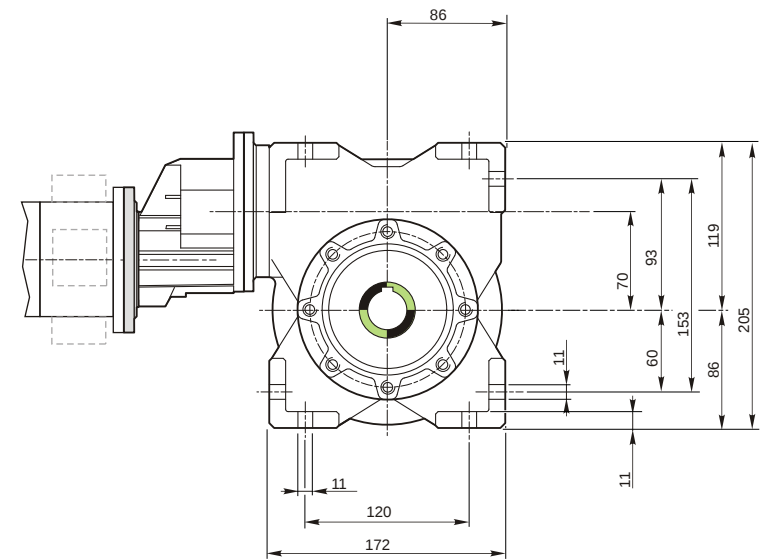
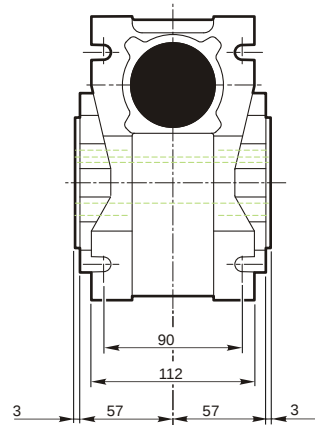
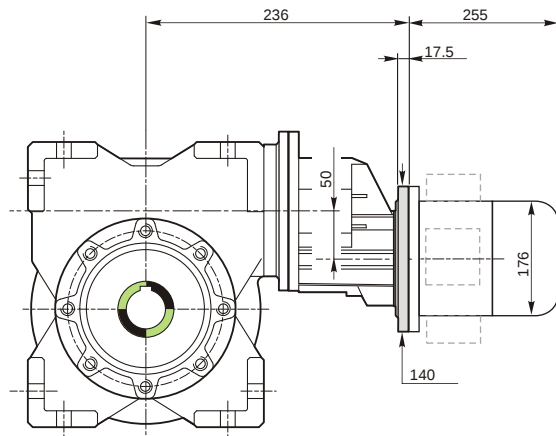

94.988
94.966

Hollow output shaft

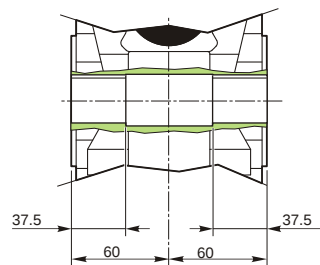
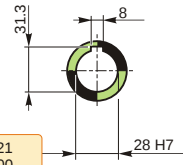

Attachment position

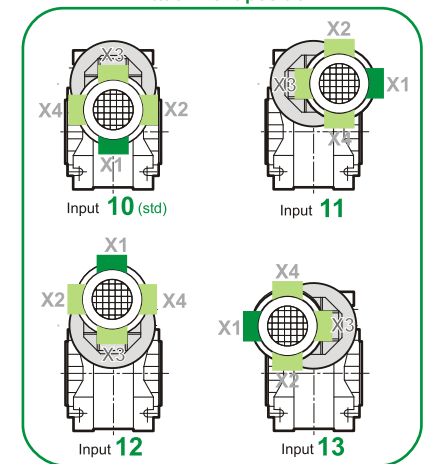

M TA 80/70 B3 10 44.8 90 B14 AC 28 MT 1.1 kW 90 S4 B14 X3

Mounting positions

B3

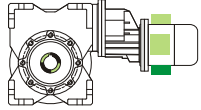

B6

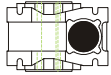

B7

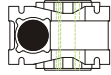

B8

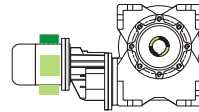

V5

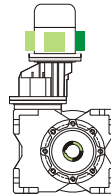

V6



Terminal box position

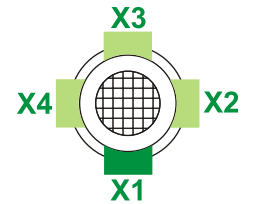

0.1	1	
0.35	2	

← Oil quantity [litres]

Lubricant type: Long life synthetic oil ISO VG320

Direction of rotation

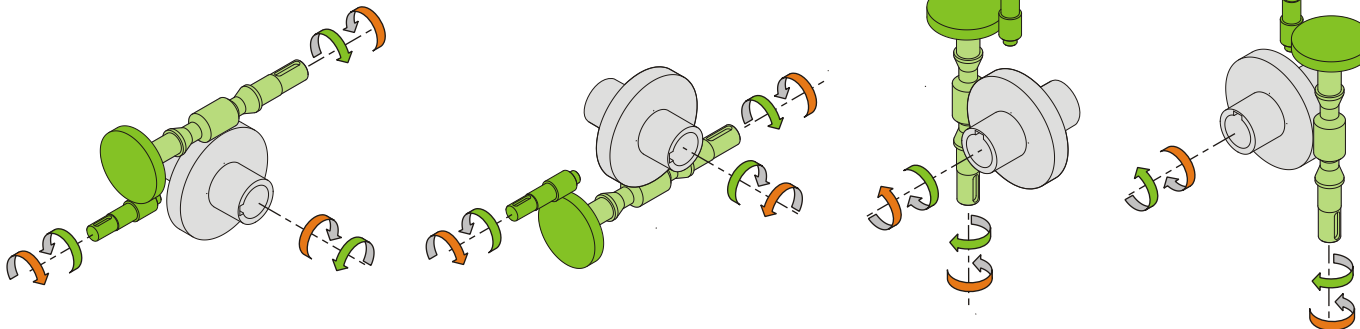

Weight

Gear unit [kg]	13
Electric motor [kg]	12

Gearing data

Axial module	3.9
Number of starts	4
Lead angle	26° 51'
Pressure angle	20°

Backdriving

- Static back-driving
- Quick back-driving
- Dynamic back-driving

M TA 80/70 B3 10 44.8 90 B14 AC 28 MT 1.1 kW 90 S4 B14 X3